



MOTOR TRIKE
I N C O R P O R A T E D



**ADVENTURE & PHOENIX OWNER'S
MANUAL**

MOTOR TRIKE INCORPORATED
P.O. Box 611
22667 FM 15
Troup, Texas 75789-0611
(800) 90- TRIKE

(The Adventure is based on the GL1800 and the Phoenix on the GL1500)

TABLE OF CONTENTS

INTRODUCTION	3
SAFELY OPERATING YOUR TRIKE.....	3
CAPACITY LIMITS	4
SPECIFICATIONS.....	5
AIR SUSPENSION OPERATION.....	6
APPROPRIATE AIR SUSPENSION PRESSURES.....	8
TRUNK OPERATION	9
PARKING.....	10
AVAILABLE ACCESSORIES & OPTIONS	11
MAINTENANCE	13
WARRANTY	16
THANK YOU.....	16



INTRODUCTION

Congratulations on acquiring your new Motor Trike conversion. Please take the necessary time to become familiar with your vehicle by reading this owner's manual. The more you know and understand about your particular unit the safer and more enjoyable your riding experience will be.

This manual is a supplement to the motorcycle owner's manual, not a replacement for it. Follow all procedures required and recommended by the motorcycle owner's manual.

For more information on Motor Trike, Inc. and the products we offer, please visit our website.

WWW.MOTORTRIKE.COM

SAFELY OPERATING YOUR TRIKE

Motor Trike is committed to offering safe vehicle platforms which accommodate user friendly operation; however, it is necessary for the user to take precautions and follow safety guidelines while operating the vehicle. In order to safely operate your trike, please carefully follow these guidelines as well as the general guidelines for motorcycle operation which can be found in the original motorcycle manual:

- Only operate the vehicle if you have the proper licensing in your state. Most states require a motorcycle license or a trike license to operate a three wheeled vehicle.
- Always wear a helmet and appropriate safety gear while operating/riding this vehicle.
- Become familiar with the vehicle's controls before operating the vehicle, using the motorcycle's owner's manual as a reference.
- Follow all traffic laws while operating the vehicle.
- Notice the sticker located on your unit's fuel tank and/or trunk door inner skin: **DO NOT LEAN. STEER THROUGH TURNS.** Unlike a motorcycle, a trike has to be steered through the turns. Refer to Figure 1.



Figure 1: Vehicle operation warning sticker

- Follow the maintenance schedule for your particular model in order to ensure the vehicle is mechanically functioning properly. The maintenance schedule can be found in the Maintenance/Service section of the Owner's Manual.
- Do not load the trike with passengers, cargo, accessories, etc. that will result in exceeding the recommended load capacity. This will ensure the vehicle is operating within its designed conditions.

CAPACITY LIMITS

In order to ensure safe operating conditions for your trike, it is imperative to follow the load limits and guidelines listed below in Table 1. These guidelines and load limits are a combination of the motorcycle manufacturer's recommended capacity limits, found in the original owner's manual, and Motor Trike's capacity limits.

Table 1: Adventure and Phoenix Capacity Limits

CAPACITY	LIMIT	DESCRIPTION
MAXIMUM TOTAL WEIGHT CAPACITY	510 LBS	DRIVER, PASSENGER, TRAILER TONGUE WEIGHT, ALL CARGO & ACCESSORIES
MAXIMUM TOTAL CARGO CAPACITY	71 LBS	TOTAL CARGO CAPACITY OF THE TRIKE
TOUR TRUNK CAPACITY	20 LBS	
TRIKE TRUNK CAPACITY	40 LBS	
FAIRING POCKET CAPACITY (2 PER TRIKE)	4.5 LBS	
TOUR TRUNK POCKET CAPACITY (2 PER TRIKE)	1.0 LBS	
MAXIMUM TRAILER TONGUE WEIGHT	100 LBS	
MAXIMUM TRAILER WEIGHT	400 LBS	EXCLUDED FROM MAXIMUM TOTAL WEIGHT CAPACITY
GROSS VEHICLE WEIGHT RATING (GVWR)	1707 LBS*	MAXIMUM TOTAL VEHICLE WEIGHT
GROSS AXLE WEIGHT RATING FRONT (GAWRF)	485 LBS	MAXIMUM TOTAL WEIGHT ON FRONT WHEEL
GROSS AXLE WEIGHT RATING REAR (GAWRR)	1222 LBS*	MAXIMUM TOTAL WEIGHT ON REAR WHEELS

YOUR TRIKE HAS BEEN DESIGNED TO CARRY ONE DRIVER AND ONE PASSENGER. DIFFERENCES IN ACCELERATION AND BRAKING MAY BE NOTICED WHEN RIDING WITH AND WITHOUT A PASSENGER, CARGO, OR TRAILER. AS LONG AS THESE ITEMS ARE WITHIN THE GIVEN LOAD LIMITS AND GUIDELINES, SAFE OPERATION OF THE TRIKE CAN STILL BE ACHIEVED.

PLEASE NOTE THAT EXCEEDING THE MAXIMUM WEIGHT CAPACITY OR IMPROPERLY LOADING YOUR TRIKE CAN SERIOUSLY IMPAIR THE TRIKE'S HANDLING, BRAKING, AND STABILITY. DISREGARDING THE LOAD LIMITS AND GUIDELINES OUTLINED ABOVE CAN LEAD TO A CRASH, SERIOUS INJURY, OR DEATH.

*add 50 lbs for the Phoenix (GL1500)

SPECIFICATIONS

The specifications shown in Table 2 and Table 3 are taken from a base model GL 1800 Adventure kit and GL1500 Phoenix kit, respectively, without any additional accessories.

Table 2: Adventure (GL1800) Specifications

OVERALL LENGTH*:	108"
WHEEL BASE*:	69"
OVERALL WIDTH:	55"
TRACK WIDTH	43.5"
TIRE SIZE:	225/60/R15
WHEEL SIZE:	15"x7" 5x4.5"
MAX LOAD CAPACITY	510 lbs

Table 3: Phoenix (GL1500) Specifications

OVERALL LENGTH*:	107"
WHEEL BASE*:	66.5"
OVERALL WIDTH:	55"
TRACK WIDTH	43.5"
TIRE SIZE:	225/60/R15
WHEEL SIZE:	15"x7" 5x4.5"
MAX LOAD CAPACITY	510 lbs

*The wheel base is measured with the stock rake. With a 4 ½" degree rake, the wheel base and overall length is increased by 3".

AIR SUSPENSION OPERATION

An on-board air compressor allows for on-the-fly air suspension pressure adjustment on both the Adventure and Phoenix. See the appropriate section below for operation directions.

ADVENTURE OPERATION:

The pressure is adjusted using the stock preload adjustment button. The air spring pressure and battery voltage display replaces the MEMO 1 and MEMO 2 buttons found on the same panel. To increase air spring pressure, press and hold the "UP" button until the desired pressure is reached. To reduce the pressure, press the "DOWN" button. **DO NOT OPERATE THE VEHICLE WITH LESS THAN 15 PSI OR MORE THAN 100 PSI IN THE AIR SPRINGS.** Figure 2 shows the air compressor control panel.



Figure 2: Air suspension control panel

The suspension control module also displays the voltage of the system. The acceptable range for your vehicle's voltage is between 11V and 14V. If the displayed voltage is greater than 14 volts, contact your local Motor Trike dealer to have the electrical system inspected on your vehicle. If the displayed voltage is below 11V despite how much you have ridden the bike, you may have a problem with the bike's charging system. Follow the recommended procedure for inspecting and charging the battery found in your owner's manual. If this does not resolve the issue, contact your local Motor Trike dealer for assistance.

PHOENIX OPERATION:

The pressure is adjusted using the stock air pressure control buttons on the right side of the bike. See Figure 3. Hold the "P. CHECK" button and press "INCREASE" or "DECREASE" until the pressure reaches the desired level. While holding down the "P. CHECK" button the current air pressure is displayed on the screen between the tachometer and speedometer. **DO NOT OPERATE THE VEHICLE WITH LESS THAN 15 PSI OR MORE THAN 100 PSI IN THE AIR SPRINGS.**



Figure 3: Air pressure control panel

APPROPRIATE AIR SUSPENSION PRESSURES

In order to ensure proper tire wear, ground clearance, and handling characteristics please follow the guidelines listed on the sticker, shown in Figure 4, found on your vehicle's fuel tank door as well as in the interior of the trunk. These guidelines are set in order to ensure the riders safety and comfort. If your vehicle is not equipped with the sticker, refer to Figure 4. **DO NOT OPERATE THE VEHICLE WITH LESS THAN 15 PSI OR MORE THAN 100 PSI IN THE AIR SPRINGS.**



MOTOR TRIKE INCORPORATED				
WEIGHT (LBS) PASSENGERS + CARGO	200	300	400	500
PRESSURE (PSI) AIR SPRINGS	25	35	50	65
PLEASE FOLLOW THE ABOVE RECOMMENDATIONS TO ENSURE PROPER TIRE WEAR, GROUND CLEARANCE, AND RIDE PERFORMANCE. DO NOT LEAN. STEER THROUGH TURNS.				

Figure 4: Location of the air suspension pressure recommendation sticker

TRUNK DOOR OPERATION

ADVENTURE TRUNK OPERATION:

The trunk door is opened by pulling either the right or left saddle bag lever under the lower edge of the tour trunk. The trunk door is usually operated with the right saddle bag release lever. However, it can be connected to the left saddle bag release lever depending on preference during kit installation. See Figure 5.

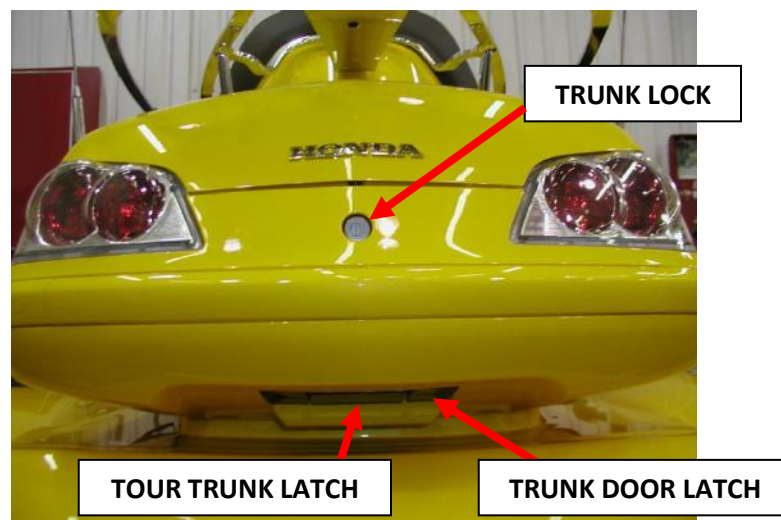

Figure 5: Trunk door operation

- The trunk in the Adventure is locked and unlocked simultaneously with the tour trunk. The key slot for the trunk lock can be seen in Figure 5 above. The key fob can be used as well (if equipped).
- To close the trunk, place your hands on the upper corners of the door and press firmly until it latches.
- If the trike trunk is left open the information screen on your dash will indicate that it has been left open by showing that a saddle bag is open. Early models of the Adventure do not include this feature.

NOTE: Before pulling on the latch, please make sure the trunk is unlocked. The latch mechanism that came with the GL1800 is fragile and can be bent or broken if you attempt to

operate it when it is locked. If the latch mechanism is bent, broken, or inoperable there is a secondary pull cord behind the right side cover. It will only operate if the trunk is unlocked.

PHOENIX TRUNK OPERATION:

The trunk door is unlatched by rotating the t-handles in the open direction. Refer to Figure 6.

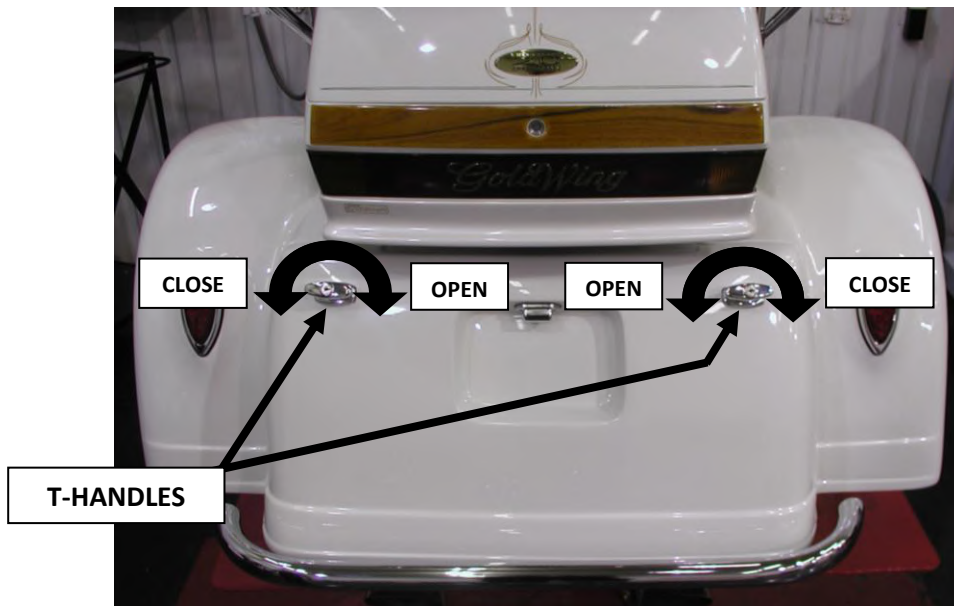

Figure 6: Opening and closing the trunk (Shown with optional chrome bumper)

- To close the trunk, place your hands on the t-handles, press the door shut, and rotate the t-handles in the closed direction shown in Figure 6.
- Lock both t-handles with the keys provided with your trike. If you lose your keys please contact your local Motor Trike dealer to arrange replacements.

PARKING

A runaway vehicle can cause property damage, personal injury, or even death. When parking your trike, use these precautionary steps to ensure the vehicle does not roll away.

- Lock the steering lock.
- Leave the transmission in gear.
- Park on level ground.

- Apply parking brake (if equipped).
- If you must park on a grade, turn your front wheel so that the bike will roll into the curb.

AVAILABLE ACCESSORIES & OPTIONS

Motor Trike offers an extensive line of accessories in order to further customize your trike. All accessories and options can be ordered and installed through your local Motor Trike dealer. Accessories and options that do not require dealer installation may be ordered directly through Motor Trike. See Table 4 for a list of our most popular accessories and options.

Table 4: Available Accessories and Options

ACCESSORIES/OPTIONS	DESCRIPTION
WIDE SELECTION OF WHEELS	CUSTOMIZE YOUR TRIKE WITH NEW REAR WHEELS OR ADD A MATCHING FRONT WHEEL.
REAR SPOILER*	ADD SOME SERIOUS STYLE TO YOUR RIDE
FENDER BRAS PLAIN	PROTECT THE FRONT OF YOUR TRIKE FENDERS
FENDER BRAS EMBROIDERED	LOOK GOOD PROTECTING YOUR TRIKE FENDERS
TRUNK CARPET	GIVE YOUR TRUNK A FINISHED LOOK
EMBROIDERED TRUNK MAT	PROTECT YOUR TRUNK CARPET WITH STYLE
4 ½° RAKE KIT	REDUCE STEERING EFFORT AND RIDER FATIGUE
CHROME NERF BUMPER	CUSTOMIZE YOUR TRIKE WITH A CHROME BUMPER
LIGHT BAR	CUSTOMIZE YOUR TRIKE AND BE MORE VISIBLE
CENTRAMATICS	INCREASE FRONT TIRE LIFE WITH A SMOOTH FRONT END
AQUA SHIELDS	PROTECT YOUR FEET FROM THE ELEMENTS WITH STYLE
FOG LIGHTS FOR AQUA SHIELDS	SEE AND BE SEEN WITH THIS GREAT ADDITION
ANTI-LOCK BRAKING SYSTEM*	KEEP YOUR STOCK ABS FULLY FUNCTIONAL ON YOUR TRIKE
TRAILER RECEIVER HITCH	PULL ONE OF OUR TRAILERS THAT MATCHES YOUR TRIKE
GLT TRAILER	ADD 4 TIMES MORE STORAGE IN A SLEEK PACKAGE
TRIKE COVER	PROTECT YOUR TRIKE
MOTOR TRIKE LUGGAGE BAG	LUGGAGE THAT MATCHES YOUR TRIKE
PARKING BRAKE	KNOW YOUR TRIKE ISN'T GOING TO ROLL AWAY!
ECHO EXHAUST	ADD A DISTINCT SOUND TO YOUR TRIKE
CUSTOM PAINT	GET THE LOOK YOU WANT THAT NO ONE ELSE HAS

*Feature not available for the Phoenix (GL1500)

For more information visit us at WWW.MOTORTRIKE.COM

RECEIVER HITCH & DRAW BAR



Proper installation of the draw bar into the receiver hitch is critical for your safety. The bolt located under the receiver tube is not intended to retain the draw bar. Its purpose is to eliminate rattling noise. The draw bar pin and safety pin must be installed. Refer to Figure 7 and Figure 8 below.

In order to properly install the draw bar:

- Loosen the bolt located on the bottom of the receiver tube.
- Slide the draw bar into the receiver tube.
- Insert the draw bar pin through the receiver tube and the hole in the draw bar.
- Clip the safety pin into the groove on the draw bar pin.
- Tighten the bolt under the receiver tube against the draw bar to prevent it from rattling.

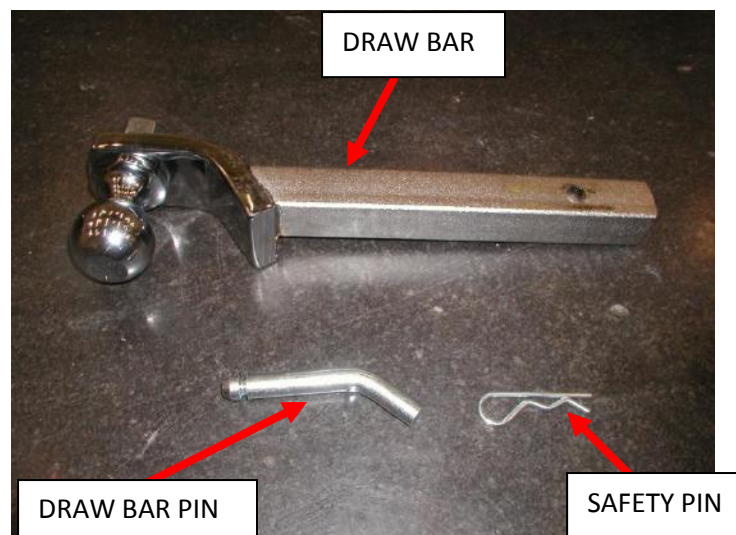

Figure 7: Draw bar components

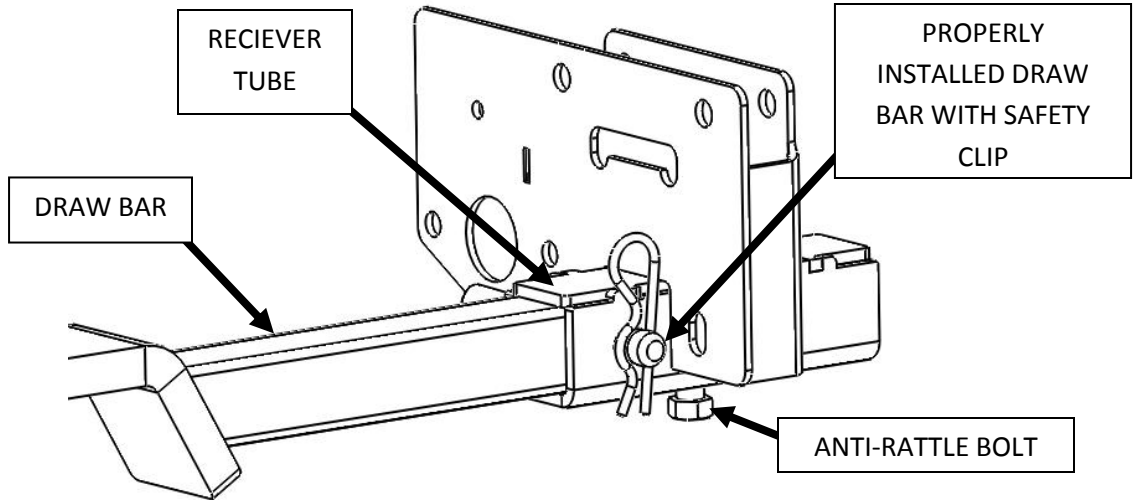

Figure 8: Properly installed draw bar safety pin

MAINTENANCE

If your vehicle requires professional services, Motor Trike has an extensive dealer network with specially trained technicians capable of servicing or repairing your vehicle. To locate the authorized Motor Trike dealer nearest you, go to the Motor Trike web site (WWW.MOTORTRIKE.COM) and access the Dealer Locator link. To help ensure your vehicle is serviced at the proper intervals, we have included a maintenance schedule found below in Table 5.

Table 5: Maintenance Schedule

COMPONENT	FREQUENCY (Miles)				
	DAILY	3,000	6,000	12,000	100,000
Tire Pressure	X				
Balance Wheels and Tires				X	
Air Suspension Pressure	X				
Lighting	X				
Brake Fluid		X			
Drive Shaft/U-Joints			XL		
Brake Rotors/ Pads			X		
Torque Rear Lug Nuts to 85 ft-lbs		X			
Rear End Oil*					R
CV Boots			X		
Suspension Alignment				X	

X: Inspect, Adjust, Replace if necessary
R: Replace
L: Lubricate using recommended lubricant
 *-Must have vacuum pump

WHEELS AND TIRES

Having properly inflated tires is essential to a comfortable and safe ride. The tire pressures on your unit should be checked before each use, this includes both the front and rear tires. Motor Trike recommends 24 PSI (166 KPa) for the rear tires. Follow the front tire air pressure recommendations provided by the motorcycle manufacturer. Improper tire inflation can result in a drastic change in handling characteristics including but not limited to head shake, vibration, increased body roll, and a stiff ride. Improper tire inflation can also lead to a tire blow out. Check your tire pressure before you go on every ride.

Improper tire and wheel balancing can result in vibrations at any speeds. To prolong the life of your tires, it is suggested to have the tires and wheels balanced every 12,000 miles. Tire maintenance and replacement are vital to your vehicle's performance. If you are experiencing uneven or improper tire wear, the alignment needs to be checked at your local Motor Trike dealer. To ensure safety, performance, and reliability, Motor Trike does NOT recommend changing the tire or wheel sizes. The rear lug nuts should be torqued to 85 ft-lbs every 3,000 miles.



AIR SUSPENSION PRESSURE

Be sure to check that your suspension air pressure is within the recommended range before and during every ride.

LIGHTING

Check that all lights are working properly before you ride your trike. This includes the brake lights, head lights, turn signals, and marker lights.

DRIVE SHAFT

At each 6,000 mile interval, it is necessary to grease the U-Joints on the drive shaft. Using automotive grade moly based grease and a grease gun, apply grease to the fitting located on the front and rear U-Joints.

DIFFERENTIAL OIL

It is only necessary to change the differential oil every 100,000 miles. A vacuum pump is needed to pump the differential oil out of the housing through the fill plug on the front of the rear end housing. This can be done by an authorized Motor Trike dealer. The acceptable oil level is 3/8" to 1/2" below the fill plug.

CV BOOTS

The CV boots should be cleaned and checked at 6,000 mile intervals. Clean the CV boots by wiping them down with a rag; do not use any chemicals. Thoroughly inspect the boots for cracks, tears, or holes which could allow contaminants to damage the CV joints. If you do encounter any damage to the CV boots, contact your local Motor Trike dealer and have it replaced as soon as possible. Prolonged use of the vehicle with a damaged CV boot will cause damage to the CV joint and surrounding components.

SUSPENSION ALIGNMENT

In order to increase the life of the tires and to ensure proper ride and handling characteristics, the rear suspension alignment should be checked every 12,000 miles by an authorized Motor Trike dealer. If you notice that the tires are wearing prematurely or in an unusual fashion, have the alignment checked before the 12,000 mile increment.

ELECTRICAL

The trike kit wire harness, which powers and controls all of the electrical items on the trike kit, is connected to the battery under the seat. If you experience an electrical problem with any of the trike electrical systems check the in-line 15 amp fuse located on the wire running to the battery. **DO NOT REPLACE THE FUSE WITH ONE OF HIGHER VALUE.** If you replace the fuse and it blows again please contact your local Motor Trike dealer.

WARRANTY

Your Motor Trike, Inc. trike kit carries a 3 year/ 60,000 mile warranty. The start date of warranty coverage will be determined by the registration date of the warranty card or online warranty registration.

Any modification or changes to the Motor Trike kit, failure to follow the guidelines noted above and/or improper maintenance will void all warranties. Misuse, abuse, accidents, unreasonable use, or Acts of God will not be covered under warranty. Normal wear items are not covered under warranty.

THANK YOU

Thank you for purchasing our trike conversion. We hope you have many safe, comfortable riding miles on our product. We invite you, in your travels, to stop by our manufacturing plant in Troup, Texas, for a tour and to meet the people who designed and manufactured your Motor Trike. We believe you will be impressed by what you witness and the people you will meet.

Again, thank you for your business and we look forward to meeting you in the future.